

Purpose:

This Application Guide describes the sources of input bias current on a high sensitivity instruments such as a null meter, the impact input bias current can have on measurements and how the user compensates for input bias current to minimize its impact on measurements.

Background:

Modern solid-state amplifiers, such as those used in null meters, use bipolar or field effect transistors (FETs). Even though the amplifier is designed for very high-gain and very low-signal operation, a small amount of current flows into or out of the amplifier's input. This is true for either bipolar transistor or FET amplifiers. This current is the amplifier's input bias current. Input bias current is usually measured in nano- or pico-amperes for high-sensitivity amplifiers. The current must have a path from the amplifier input to circuit common. Often this path is through the external measurement circuit connected to the instrument.

Amplifiers designed for instrumentation work often have differential inputs (see Figures 1a and 1b). The amplifier output signal is a function of the *difference* between the signals applied to the two inputs. In the case of differential amplifiers, each input has its own input bias current. The difference between these two currents is known as the input offset current. This is shown in Figure 1 as $I_{off} = I_{b2} + I_{b1}$. The direction of the current (in or out) depends on which current (I_{b2} or I_{b1}) is larger.

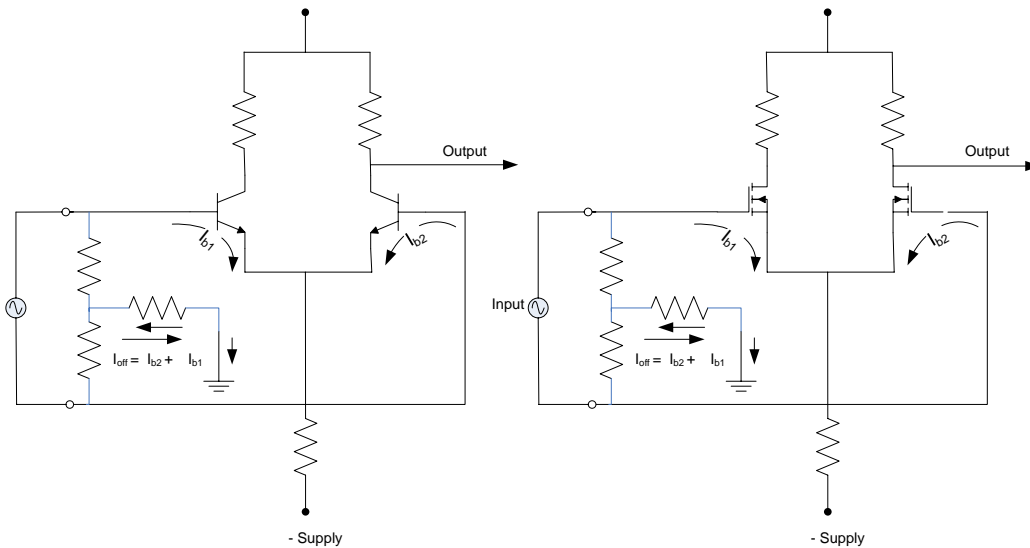

Figure 1a

Figure 1b

In general the user does not need to know if an amplifier is single-ended or differential. What concerns the user is the small current (I_b) flowing into or out of the instrument input terminals. See Figure 2.

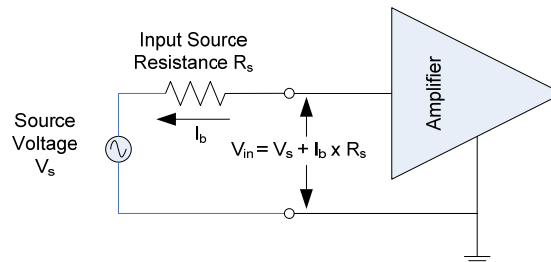

Figure 2

This current flows through the source resistance (R_s) of the signal source driving the amplifier input. If that signal source has a high-impedance, the small current from the amplifier's input causes an additional voltage drop ($V_{\text{loff}} = I_b \times R_s$). That small voltage drop also appears at the amplifier's input terminals. This results in an error as it either adds to or is subtracted from (depending on the direction of the bias current flow) the signal of interest.

Solving the Problem:

A modern instrument design includes an adjustable circuit to inject a current that is equal and opposite to the amplifier bias current. In some cases, such as with the PPM AVM-2000, this is a user adjustable value. This allows the operator to balance out any amplifier bias current as well as to balance out any other unwanted current that may exist in the input circuit. Making the input offset current adjustable also allows the operator to compensate for input bias current changes that occur with changes in temperature, component aging, electromagnetic environment, etc.

The Technique:

Compensating for input bias current is a two-step process.

First, adjust the amplifier to remove the effects of any VOLTAGE offset. Voltage offset is adjusted by shorting the amplifier's input (using a very low resistance that exhibits little or no thermal voltage—see Application Guide AG-105) and adjusting the amplifier's voltage offset until the amplifier output is zero.

Second, create a source resistance that is high enough that a small input bias current flowing through the resistance generates a measurable voltage. If the measurement source resistance is not known, a suitable value for such a resistance is 100,000 Ω . The shorting strap used to adjust the voltage offset is replaced with this low-noise (carbon film or metal film) 100,000 Ω resistor. At this point any output voltage shown is the amplified version of the product (Ohm's Law) of the input bias current and the resistor value.

For example, a 1 nA input bias current flowing in a 100,000 Ω resistor produces 100 μV at the amplifier input. With the resistor in place, the instrument's input offset current control is adjusted to provide a current that is equal and opposite to the amplifier's input bias current. When the two currents are equal and opposite, no current flows through the resistor and therefore no voltage is developed across the resistor. With zero volts at the input, the amplifier output is zero. At this time, there should be no difference in the amplifier output between a shorted input (0 Ω) and a 100,000 Ω resistor at the input.

Summary:

When adjusting the Input Offset Current to compensate for Input Bias Current, keep the following in mind:

- Be sure to zero Input Offset **Voltage** before adjusting Input Bias Current.
- Voltages generated by the Input Offset Current should be large compared to voltages that might be generated by resistor noise, thermal emfs, electro-chemical emfs, etc. (10 μV to 100 μV are good ranges to use). See PPM AG-105 for a discussion of other potential sources of offset voltage.
- Input Offset Current will change with changes in the measurement environment and therefore should be checked from time-to-time. Large changes in the voltage levels of signals being measured may also change the measurement environment sufficiently to change the impact of Input Bias Current.